

INSTALLATION AND OPERATING INSTRUCTIONS

VERSA SPA HEATER

Model
055B



WARNING: If the information in these instructions is not followed exactly, a fire or explosion may result causing property damage, personal injury or death.

- Do not store or use gasoline or other flammable vapors and liquids in the vicinity of this or any other appliance.
- **WHAT TO DO IF YOU SMELL GAS**
 - Do not try to light any appliance.
 - Do not touch any electrical switch; do not use any phone in your building.
 - Immediately call your gas supplier from a neighbor's phone. Follow the gas supplier's instructions.
 - If you cannot reach your gas supplier, call the fire department.
- Installation and service must be performed by a qualified installer, service agency or the gas supplier.

This manual should be maintained in legible condition and kept adjacent to the heater or in a safe place for future reference.



WATER CHEMISTRY
(Corrosive water voids all warranties)

For your health and the protection of your pool equipment, it is essential that your water be chemically balanced. The following levels must be used as a guide for balanced water.

Recommended Level(s)	Fiberglass Pools	Fiberglass Spas	Other Pool & Spa Types
Water Temp. (Deg. F)	68 to 88	89 to 104	68 to 104
pH	7.3 to 7.4	7.3 to 7.4	7.6 to 7.8
Total Alkalinity (PPM)	120 to 150	120 to 150	100 to 150
Calcium Hardness (PPM)	200 to 300	150 to 200	80 to 100
Salt (PPM)	6000 MAXIMUM	6000 MAXIMUM	6000 MAXIMUM
Free Chlorine (PPM)*	2 to 3	2 to 3	2 to 3

*** Free Chlorine MUST NOT EXCEED 5 PPM!**

- Occasional chemical shock dosing of the pool or spa water should not damage the heater providing the water is balanced.
- Automatic chemical dosing devices and salt chlorinators are usually more efficient in heated water, unless controlled, they can lead to excessive chlorine level which can damage your heater.
- Further advice should be obtained from your pool or spa builder, accredited pool shop, or chemical supplier for the correct levels for your water.

Contents

4	PART ONE - Owner's Operating Instructions
4	SECTION 1/START-UP PROCEDURES
4	Before Start-Up
5	Lighting Instructions & Shut-Off Procedures (manually lighted MILLIVOLT pilot)
6	Operating Instructions & Shut-Off Procedures (automatically lighted IID pilot)
7	After Start-Up
7	SECTION 2/CAUTION
7	SECTION 3/MAINTENANCE & CARE PROCEDURES
8	Pool & Spa Water Chemistry
8	Winterizing the Pool and Spa Heater
9	PART TWO - Installation / Service Instructions
9	SECTION 1/RECEIVING EQUIPMENT
9	SECTION 2/GENERAL SPECIFICATIONS
9	SECTION 3/INSTALLATION INSTRUCTIONS
9	Code Requirements
9	Base Installation
9	Clearances
11	Combustion Air
11	Venting Connections
13	Gas Supply Connections
14	Plumbing for Water Connections
15	Electrical Wiring
17	Wiring Diagrams
19	SECTION 4/SERVICING INSTRUCTIONS
19	General Location of Controls
19	Control Adjustments/Replacements
20	Pressure Switch
20	Flame Roll-Out Safety Switch
20	High Limit
20	High Limit Removal
20	Pilot Safety
21	Burner tray Removal
21	Gas Valve
21	Main Burner & Orifice
21	Pilot Removal & Cleaning
21	Heat Exchanger Removal
22	Desooting Procedure
22	Combustion Chamber Removal
22	Control Immersion Well Replacement
22	Unitherm Governor Replacement
23	SECTION 5/TROUBLESHOOTING GUIDE
23	Mechanical
24	Electrical MILLIVOLT Units
25	Electrical IID Units
27	SECTION 6/REPLACEMENT PARTS

PART ONE - OWNER'S OPERATING INSTRUCTIONS

FOR YOUR SAFETY - READ BEFORE OPERATING

WARNING: IF YOU DO NOT FOLLOW THESE INSTRUCTIONS EXACTLY, A FIRE OR EXPLOSION MAY RESULT, CAUSING PROPERTY DAMAGE, PERSONAL INJURY OR LOSS OF LIFE.

SECTION 1 / START-UP PROCEDURES

BEFORE START-UP

BURNERS

Clean main burners and air louvers of dust, lint and debris. Keep heater area clear and free from combustibles, flammable liquids and chemicals. Do not obstruct the flow of combustion and ventilation air.

WATER

First thing, ensure that system is filled with water and have pump operating. Water must be flowing through the heater during operation.

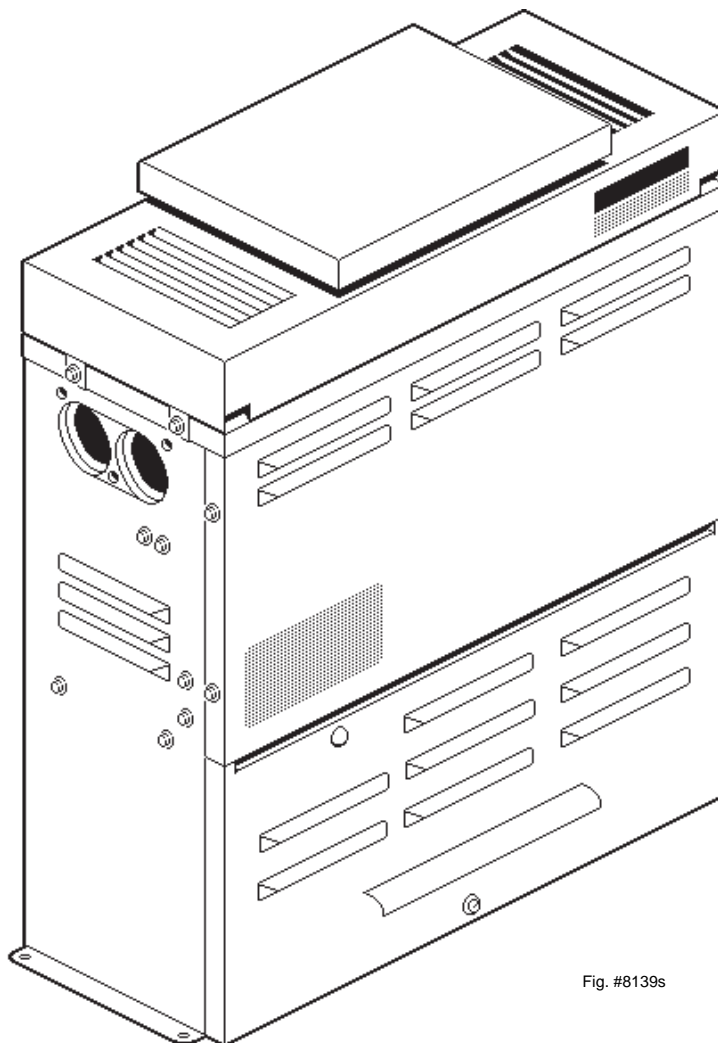

Fig. #8139s

CAUTION: Propane is heavier than air and will settle on the ground. Since propane can accumulate in confined areas, extra care should be exercised when lighting propane heaters.

LIGHTING INSTRUCTIONS AND SHUT-OFF PROCEDURES

**MANUALLY LIGHTED PILOTS
(MILLIVOLT SYSTEM)**

- A. This appliance has a pilot that must be lighted by hand. When lighting the pilot, follow these instructions exactly.
- B. BEFORE LIGHTING smell all around the appliance area for gas. Be sure to smell next to the floor because some gas is heavier than air and will settle on the floor.

*If you cannot reach your gas supplier, call the fire department.

- C. Use only your hand to push in or turn the gas control knob. Never use tools. If the knob will not push in or turn by hand, do not try to repair it. Call a qualified service technician. Force or attempted repair may result in a fire or explosion.

WHAT TO DO IF YOU SMELL GAS:

- *Do not try to light any appliance.
- *Do not touch any electric switch; do not use any phone in your building.
- *Immediately call your gas supplier from a neighbor's phone. Follow the gas supplier's instructions.

- D. Do not use this appliance if any part has been under water. Immediately call a qualified service technician to inspect the appliance and to replace any part of the control system and any gas control which has been under water.

LIGHTING INSTRUCTIONS

1. **STOP!** Read the safety information above.
2. Set the thermostat on the lowest setting.
3. Turn On-off switch to the "Off" position.
4. Remove heater door panel.
5. Push in gas control knob slightly and turn clockwise  to "Off".

NOTE: Knob cannot be turned from "Pilot" to "Off" unless knob is pushed in slightly. Do not force.

6. Wait 5 minutes to clear out any gas. If you then smell gas, **STOP!** Follow "B" in the safety information above. If you don't smell gas, go to the next step.
7. Locate pilot mounted on the left side of the burner tray. For burner tray location, see General Location of Controls section, page 17.

Gas control knobs shown in "Off" position

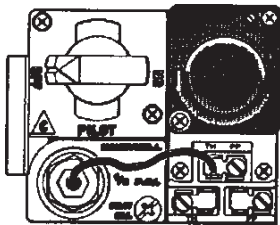

HONEYWELL
GAS VALVE
MILLIVOLT

Fig. #8081.0

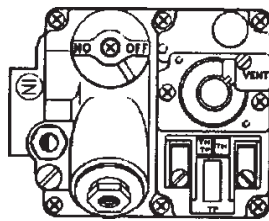

ROBERTSHAW
GAS VALVE
MILLIVOLT

Fig. # 8199

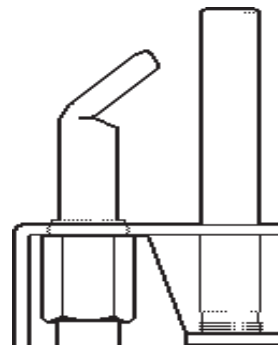

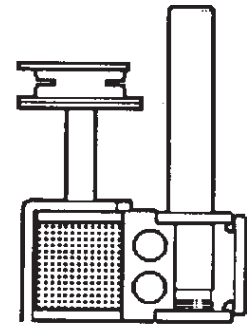

ROBERTSHAW PILOT

Fig. #8084.0



HONEYWELL PILOT

Fig. #8083.0

8. Turn knob on gas control counter-clockwise  to "Pilot".
9. Push in control knob all the way and hold in. Immediately place flame to pilot to light. Continue to hold control knob in for about 1 minute after the pilot is lighted, release knob and it will pop back up. Pilot should remain lighted. If it goes out, repeat steps 5 through 9.
 - *If knob does not pop up when released, stop and immediately call your service technician or gas supplier.
 - *If the pilot does not stay lit after several tries, turn the gas control knob to "Off" and call your service technician or gas supplier.
10. Stand to the side of the heater and turn the gas control knob counter-clockwise to  "On".
11. Replace heater door panel.
12. Turn On-off switch to the "On" position.
13. Set thermostat to the desired setting.

TO TURN OFF GAS TO APPLIANCE

1. Set the thermostat to the lowest setting.
2. Turn On-off switch to the "Off" position.
3. Remove heater door panel.
4. Push the gas control knob slightly and turn clockwise to  "Off". Do not force.
5. Replace heater door panel.

CAUTION: Propane is heavier than air and will settle on the ground. Since propane can accumulate in confined areas, extra care should be exercised when lighting propane heaters.

OPERATING INSTRUCTIONS AND SHUT-OFF PROCEDURES
AUTOMATICALLY LIGHTED PILOTS
(ELECTRONIC IGNITION SYSTEMS)

- A. This appliance is equipped with an ignition device which automatically lights the pilot. Do not try to light the pilot by hand.
- B. BEFORE OPERATING, smell all around the appliance area for gas. Be sure to smell next to the floor because some gas is heavier than air and will settle on the floor.



WHAT TO DO IF YOU SMELL GAS:

- *Do not try to light any appliance.
- *Do not touch any electric switch; do not use any phone in your building.
- *Immediately call your gas supplier from a neighbor's phone. Follow the gas supplier's instructions.

*If you cannot reach your gas supplier, call the fire department.

- C. Use only your hand to push in or turn the gas control knob. Never use tools. If the knob will not push in or turn by hand, do not try to repair it; call a qualified service technician. Force or attempted repair may result in fire or explosion.
- D. Do not use this appliance if any part has been under water. Immediately call a qualified service technician to inspect the appliance and to replace any part of the control system and any gas control which has been under water.

OPERATING INSTRUCTIONS

1. **STOP!** Read the safety information above.
2. Set the thermostat to the lowest setting.
3. Turn off all electric power to the appliance.
4. This appliance is equipped with an ignition device which automatically lights the pilot. Do not try to light the pilot by hand.
5. Remove heater door panel.
6. Push in gas control knob slightly and turn clockwise  to "Off".
Knob cannot be turned to "Off" unless it is pushed in slightly. Do not force.
7. Wait 5 minutes to clear out any gas. If you then smell gas, **STOP!** Follow "B" in the safety information previously stated. If you don't smell gas, go to the next step.
Gas control lever shown in the "On" position.
8. Turn gas control knob counter-clockwise  to "On".

Gas control knob shown in "ON" position.

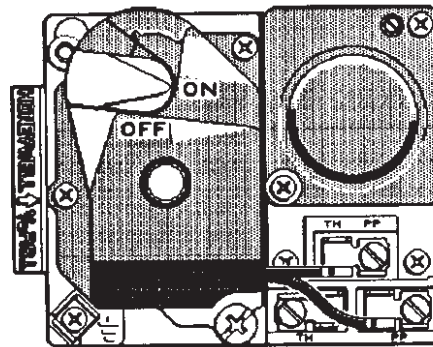

GAS VALVE-IID Fig. # 8112

9. Replace heater door panel.
10. Turn on all electrical power to appliance.
11. Set thermostat to desired setting.
12. If the appliance will not operate, follow the instructions "To Turn Off Gas To Appliance" and call your service technician or gas supplier.

TO TURN OFF GAS TO APPLIANCE

1. Set the thermostat at the lowest setting.
2. Turn off all the electric power to the appliance if service is to be performed.
3. Remove heater door panel.
4. Push in gas control knob slightly and turn clockwise  to "Off".
5. Replace heater door panel.

AFTER START-UP

Feel the inlet and outlet pipes. Outlet pipe should be only slightly warmer than the inlet. It should not be hot.

WARNING: *Should overheating occur or the gas supply fail to shut-off, turn off the manual gas control valve to the appliance.*

VISUAL INSPECTION

With the heater on, remove the door and make a visual check of the pilot and burner. The flame should be blue with a well-defined pattern.

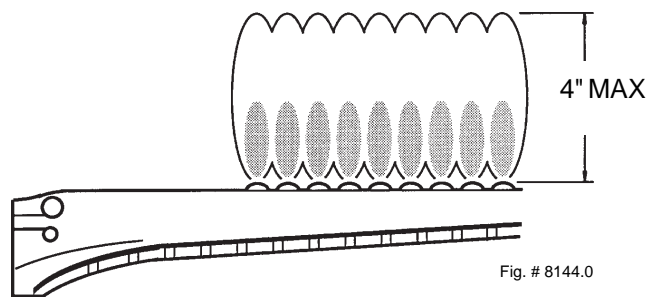

MAIN BURNER FLAME

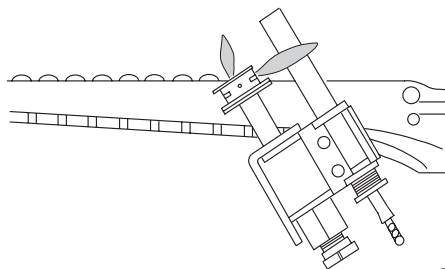

PILOT BURNER FLAME

A yellow or "floating" flame indicates restricted air openings or incorrect orifice size. Should this occur, shut the heater off and contact your installer or gas supplier.

WATER PRESSURE SWITCH

A water pressure switch is provided in the heater to shut-off the burners in the event that water supply to the heater is interrupted. It is very important to verify that the switch electrically opens and shuts off the gas valve when water flow to the heater is interrupted. Otherwise, rapid and severe heater damage will likely occur. (The water pressure switch should be checked and adjusted for proper operation by a qualified service person at the time of installation and periodically checked thereafter. Refer to pressure switch servicing instruction in Section 4 of this manual.)

WARNING: *Operation of the heater without water circulation will cause rapid and severe damage to the heater.*

SECTION 2 / CAUTION

Elevated water temperature can be hazardous, and the U.S. Consumer Product Safety Commission recommends the following guidelines:

1. Spa or hot tub water temperatures should never exceed 104°F (40°C). A temperature of 100°F (38°C) is considered safe for a healthy adult. Special caution is suggested for young children.
2. Use of drugs and/or alcoholic beverages before or during spa or hot tub use may cause drowsiness which could lead to unconsciousness and subsequently result in drowning.
3. *Pregnant women beware!* Soaking in water over 102° F (39°C) may cause fetal damage during the first three months of pregnancy, including brain damage or deformity. Pregnant women should observe the 100°F (38°C) maximum rule.
4. Before entering the spa or hot tub, users should check the water temperature with an accurate thermometer; spa or hot tub thermostats may err in regulating water temperatures by as much as ± 4 °F (2.2°C).
5. Persons with a medical history of heart disease, circulatory problems, diabetes, or blood pressure problems should obtain a physician's advice before using pools or hot tubs.
6. Persons taking medications which induce drowsiness, such as tranquilizers, antihistamines, or anticoagulants, should not use spas or hot tubs.

SECTION 3 / MAINTENANCE AND CARE PROCEDURES

To be followed one month after start-up and then semi-annually.

1. Inspect top of heater and draft hood for soot, a sticky black substance found around finned tubes, baffle and open flue gas passageways.

CAUTION: *Soot may be combustible. Wet sooted surfaces completely prior to cleaning. Do not use steel wire brush.*

2. Clean main burners and pilot burner of dust and lint.
3. Inspect and operate all controls, gas valve and pressure relief valve.

4. Make visual check of the burner and pilot flame. Flame pattern on the main burner and pilot is indicated in the previous illustration. Yellow flame means restriction of the air openings. Lifting or blowing flame indicates high gas pressure. Low flame means low gas pressure. Should this occur, shut the heater off and contact your gas supplier or qualified service agency.
5. On indoor heaters, clean room intake openings to ensure adequate flow of combustion and ventilation air.

CAUTION: *Combustion air must not be contaminated by corrosive chemical fumes which can damage the heater and void the warranty.*

6. Keep area around heater clear and free from combustible materials and other flammable and corrosive vapors and liquids.

BASIC TIPS IF HEATER WILL NOT FIRE:

If you have no electrical power:

1. The "circuit breakers" may have tripped. Try re-setting them.

If you have electrical power, check the following:

1. The time clock must be moved to the "ON" position.
2. Your pump strainer basket may be full. If so remove debris.
3. Your filter may be dirty. If so, backwash or clean filter. (If your filter is dirty, the gauge pressure will be higher than usual).
4. The pump may have lost its prime and be running dry. Check the pressure gauge on the filter. If there is no pressure; the water is not moving (or your gauge is broken). Try to get the pump to run at its normal flow rate.

POOL & SPA WATER CHEMISTRY

Chemical imbalance can cause severe damage to your heater and associated equipment. Maintain your water chemistry according to the chart on page 2. If the mineral content and dissolved solids in the water become too high, scale forms inside the heat exchanger tubes, reducing heater efficiency and also damaging the heater. If the pH drops below 7.2, the heater will be severely damaged. This will result in corrosion of the heat exchanger. Heat exchanger damage resulting from chemical imbalance is not covered by the warranty.

COLDWEATHER OPERATION

Heater operation can continue during short term cold spells. When temperatures are below freezing, flow (continuous pump operation) must be maintained.

CAUTION: *Do not use the heater to maintain water temperatures just above freezing, or for freeze protection. When heaters are used during freezing weather, care must be taken to avoid freeze-ups. Continuous pump operation is a must. Additional protection may be required. The heater is not warranted against freeze-ups.*

Prolonged operation with water temperatures below 50°F is not recommended. When starting the heater with pool temperatures below 50°F, operate the heater continuously until higher temperatures are reached. Operating the heater for prolonged periods with pool water below 50° F can seriously damage the heater, and will void the warranty.

For cold climate areas please follow the winterizing procedures listed below.

WINTERIZING THE SPA HEATER

When heaters installed outdoors in freezing climate areas are to be shut down for the winter, observe the following procedure:

1. Turn off gas valve, manual gas valve, and electrical supply to the heater.
2. Open drain cock located on the return header.
3. Disconnect compression fittings from the pressure switch and header that connect to the 1/4" copper tube and allow the tube to drain.

PART 2 - INSTALLATION / SERVICE INSTRUCTIONS

SECTION 1 / RECEIVING EQUIPMENT

On receipt of your equipment it is suggested that you visually check for external damage to the carton. If the carton is damaged, a note should be made on the Bill of Lading when signing for the equipment. Remove the heater from the carton and if it is damaged, report the damage to the carrier immediately.

On occasion, we ship some items loose. Be sure that you receive the number of packages indicated on the Bill of Lading.

When ordering parts, you must specify model and serial number of heater. When ordering under warranty conditions, you must also specify the date of installation.

The manufacturer recommends that this manual be reviewed thoroughly before installing your pool/spa heater. If there are any questions that this manual does not answer, please contact the factory or your local representative.

SECTION 2 / GENERAL SPECIFICATION

These heaters are design certified and tested under the requirements of ANSI Z21.56/CSA 4.7 American National Standard / CSA standards for gas-fired pool heaters

The heater is interchangeable and can be used either indoors or outdoors. The appropriate top designated for that type of use is required. If desired, the top can be changed at a later date to change from outdoor to indoor or vice versa. Millivolt heaters contain a self-generating electrical system operating between .25 and .75 volts.

AMBIENT TEMPERATURE RATING OF HEATER COMPONENTS

Millivolt Heater with Honeywell Gas Valve
+32°F to +175°F

Millivolt Heater with Robertshaw Gas Valve
0°F to +175°F

Electronic Ignition Heaters*
-32°F to +175°F

*Requires 120V or 240V power supply

Rated inputs are suitable for up to 2000 feet elevation. For elevations above 2000 feet, reduce input 4% for each 1000 feet above sea level, as high elevation reduces combustion performance. For Canada, reduce input 10% when installed at 2000-4500 feet elevation.

SECTION 3 / INSTALLATION INSTRUCTIONS

CALIFORNIA PROPOSITION 65 WARNING: This product contains chemicals known to the State of California to cause cancer, birth defects or other reproductive harm.

IMPORTANT NOTICE

These instructions are intended for use by qualified personnel only, specifically trained and experienced in the installation of this type of heating equipment and related system components. Installation and service personnel may be required by some states to be licensed. If your state is such, be sure your contractor bears the appropriate license. Persons not qualified shall not attempt to fix this equipment nor attempt repairs according to these instructions.

WARNING: *Improper installation, adjustment, alteration, service or maintenance may damage the equipment, create a hazard resulting in asphyxiation, explosion or fire, and will void the warranty.*

CODE REQUIREMENTS

NOTE: *The heater should not be located in an area where possible water leakage will result in damage to the area adjacent to the appliance or to the structure. When such locations cannot be avoided, it is recommended that a suitable drain pan, adequately drained, be installed under the appliance. The pan must not restrict combustion air flow.*

Installation must be in accordance with local codes, or, in the absence of local codes, with the latest editions of the National Fuel Gas Code, ANSI Z223.1, and the National Electrical Code, ANSI/NFPA 70; for Canada, the latest edition of CAN/CGA B-149.1 and B-149.2

BASE INSTALLATION

Heater must be mounted on a level surface. It can be installed on combustible flooring. Heaters may not be installed on carpeting.

CLEARANCES

WARNING: The heater shall not be located in an area where water sprinklers, or other devices, may cause water to spray through the cabinet louvers and into the heater. This could cause heavy internal rusting or damage some electrical components, and this would void the warranty.

ALL HEATERS

Clearances from Combustible construction:

Indoor Installation

Top* (Drafthood) - 35"; Vent - 6";
Back - 2"; Right Side - 6";
Left Side - 6"; Floor - 0

Outdoor Installation

Top* (Stackless Top) -
unobstructed; Back - 2"; Sides - 6"

* Clearance from Top of Vent Terminal

For servicing, provide at least 24" in front of the heater for burner tray removal, and at least 18" on the left side of the heater to inspect and delime the heat exchanger.

OUTDOOR HEATERS

These heaters are design certified for outdoor installation, when equipped with the approved top designated for outdoor use.

Heater with outdoor top

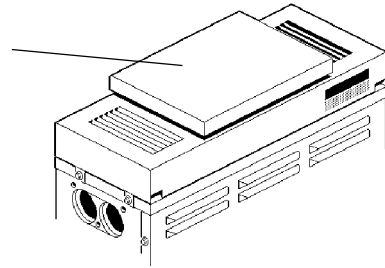

Fig. # 8139

WARNING: Do not install within 3 feet of a Heat Pump or an outdoor condensing unit. Strong air intake from this equipment can disturb the combustion process and cause damage or personal injury.

Heaters must not be installed under an overhang of less than three (3) feet from the top of the heater. Three (3) sides must be open in the area under the overhang. Roof water drainage must be diverted away from the heaters installed under overhangs with the use of gutters:

For U.S. installations, the point from where the flue products exit the heater must be a minimum of four (4) feet below, four (4) feet horizontally from or one (1) foot above any door, window or gravity inlet to a building. The top surface of the heater shall be at least three (3) feet above any forced air inlet, or intake ducts located within ten (10) feet horizontally.

For installations in Canada, pool heaters shall not be installed with the top of the vent assembly within 10 feet below, or to either side, of any opening into the building. Refer to the latest revision of CAN/CGA-B149.1 and B149.2.

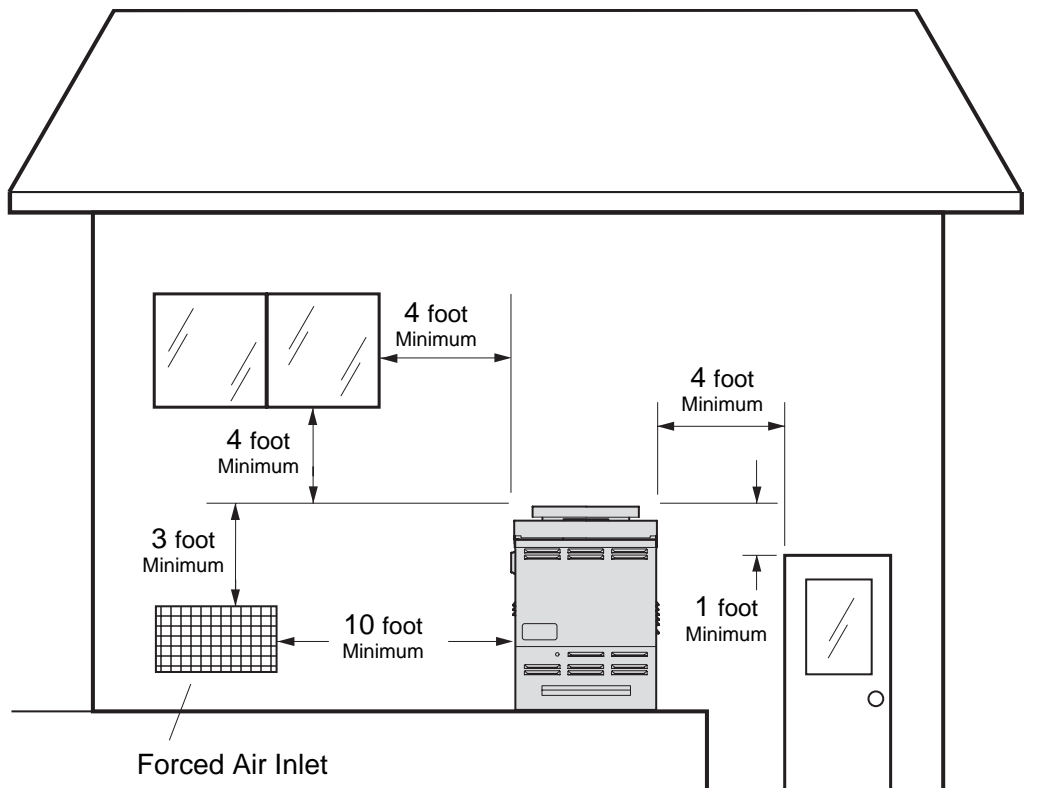

U.S. Installation Only

HIGHWIND CONDITIONS (OUTDOOR UNITS ONLY)

In areas where high winds are frequent, it may be necessary to locate the heater a minimum of 3' from high vertical walls, or install a wind break so the heater is not in direct wind current.

INDOOR HEATERS

The design is also certified for indoor installation when equipped with the approved draft hood. **For Canada**, indoor installation is restricted to an enclosure that is not occupied and does not directly communicate with occupied area. Refer to the latest edition of CAN/CGA-B149.1 and B149.2 for specific requirements. Locate heater as close as practical to a chimney or gas vent. Heater must always be vented to the outside. See Vent Piping section (pg. 11) for venting details. Minimum clearances are shown on the nameplate.

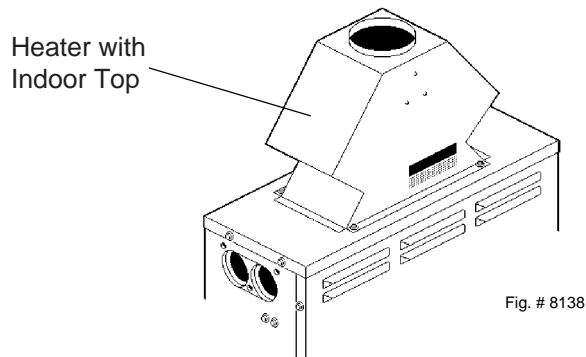

COMBUSTION AIR (INDOOR UNITS ONLY)

Air for Combustion and Ventilation
(Indoor Units Only)

The heater must have both combustion and ventilation air. Minimum requirements for net free air supply openings are one 12 inches from ceiling for ventilation and one 12 inches from the floor for combustion air as outlined in the latest edition of the National Fuel Gas Code, Z223.1(Canada-CAN/CGA-B149.1 and B149.2) and any local codes that may have jurisdiction.

CAUTION: *Combustion air must not be contaminated by corrosive chemical fumes which can damage the heater and void the warranty.*

- a. All Air from Inside the Building:
Each opening shall have a minimum of 50 net free square inches.
- b. All Air from Outdoors:
When air is supplied directly from outside of the building, each opening shall have a minimum of 13 net free square inches.

VENTING CONNECTIONS

VENT TERMINAL ASSEMBLY

Outdoor

- STEP 1: Remove the (4) screws which fasten jacket top to heater.
- STEP 2: Lower outdoor top onto unit lining up slots in outdoor top with screw holes in jacket top.
- STEP 3: Reinstall (4) screws to secure jacket top and outdoor top to unit.

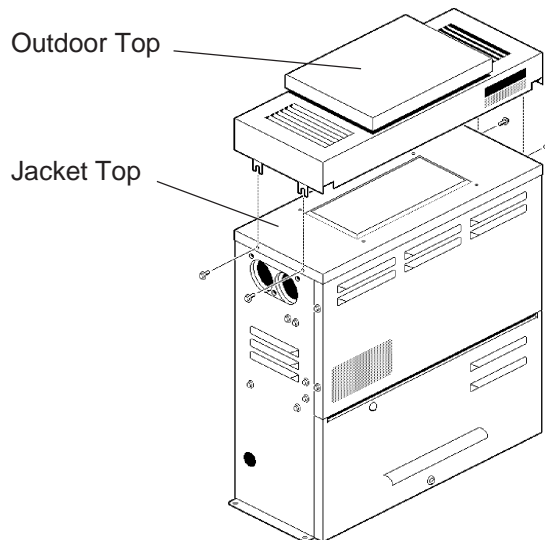

Indoor

Locate and assemble as shown. Secure with screws supplied in envelope inside carton.

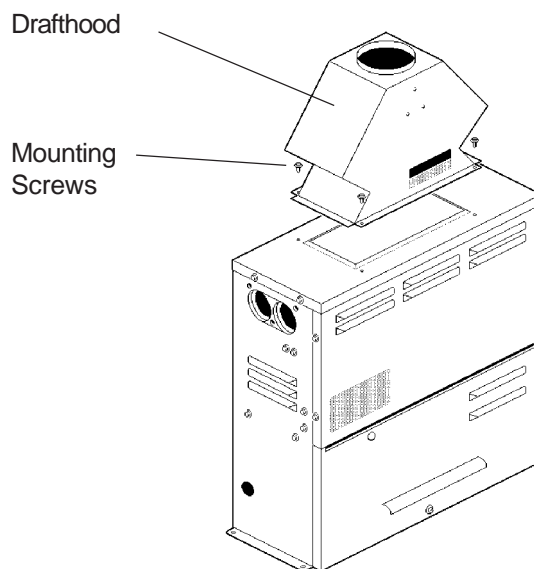

VENT PIPING

WARNING: *Indoor boilers require a draft hood that must be connected to a vent pipe and properly vented to the outside. Failure to follow this procedure can cause fire or fatal carbon monoxide poisoning.*

Vent piping the same size or larger than the draft hood outlet is recommended, however, when the total vent height is at least ten (10) feet (draft hood relief opening to vent terminal), the vent pipe size may be reduced as specified in Chapter 10 of the latest edition of the National Fuel Gas Code, **ANSI Z223.1 (Canada-CAN/CGA-B149.1 and B149.2)**. As much as possible, avoid long horizontal runs of vent pipe and too many elbows. If installation requires horizontal or non-vertical runs, the vent pipe must have a minimum of 1/4 inch per foot rise and should be supported at not more than five foot intervals. Plumbers' tape, criss-crossed, will serve to space both horizontal and vertical piping. Gas vents supported only by the flashing and extending above the roof more than five feet should be securely guyed or braced to withstand snow and wind loads. We recommend use of insulated vent pipe spacer through the roofs and walls.

For protection against rain or blockage by snow, the vent pipe must terminate with a vent cap which complies with the local codes or, in the absence of such codes, to the latest edition of the National Fuel Gas Code, **ANSI Z223.1 (Canada-CAN/CGA-B149.1 and B149.2)**.

The discharge opening must be a minimum of 2 ft. vertically from the roof surface and at least 2 ft. higher than any part of the building within ten feet. Vent stack shall be at least five feet in vertical height above the draft hood outlet. The vent cap location shall have a minimum clearance of 4 ft. horizontally from, and in no case above or below, unless a 4-foot horizontal distance is maintained from electric meters, gas meters regulators and relief equipment.

The weight of the vent stack or chimney must not rest on heater draft hood. Support must be provided in compliance with applicable codes. The heater top and draft hood must be readily removable for maintenance and inspection. Vent pipe should be adequately supported to maintain proper clearances from supported to maintain proper clearances from combustible construction.

Type "B" double wall or equivalent vent pipe is recommended. However single-wall metal vent pipe may be used as specified in the latest edition of the National Flue Gas Code **ANSI Z223.1 (Canada-CAN/CGA-B149.1 and B149.2)**.

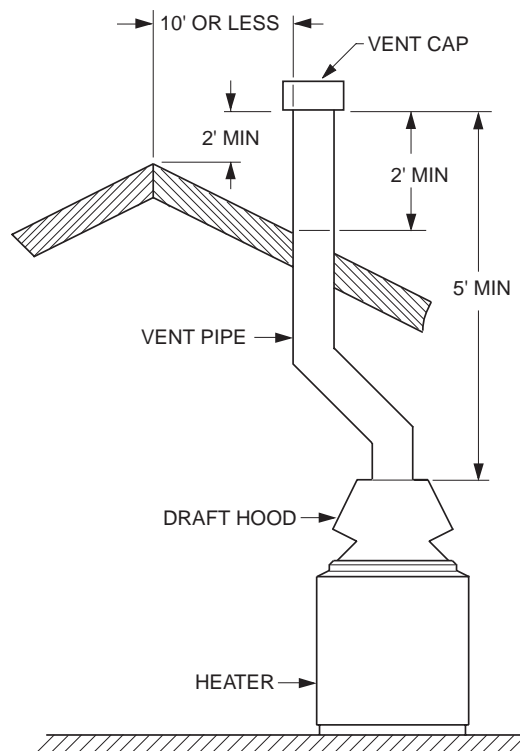

GAS SUPPLY CONNECTIONS

Gas piping must have a sediment trap ahead of the heater gas controls, and a manual shut-off valve located outside the heater jacket. All gas piping should be tested after installation in accordance with local codes.

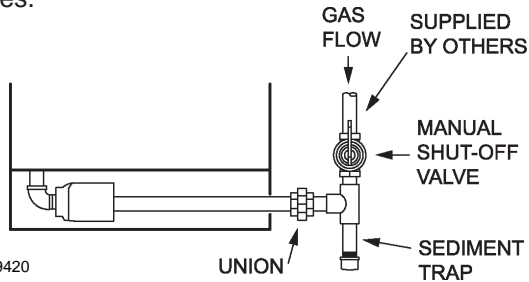

Fig. # 9420

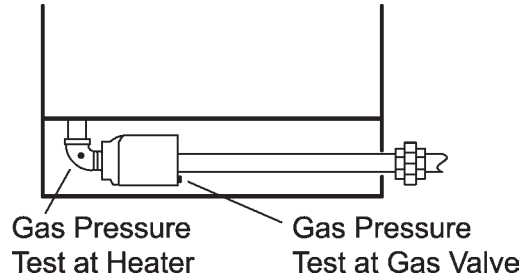

Fig. # 9421

CAUTION: The heater and its manual shut-off valve must be disconnected from the gas supply during any pressure testing of that system at test pressures in excess of 1/2 psig (3.45 KPA). Dissipate test pressure in the gas supply line before reconnecting the heater and its manual shut-off valve to gas supply line. FAILURE TO FOLLOW THIS PROCEDURE MAY DAMAGE THE GAS VALVE. OVER PRESSURED GAS VALVES ARE NOT COVERED BY WARRANTY. The heater and its gas connections shall be leak tested before placing the appliance in operation. Use soapy water for leak test. Do NOT use open flame.

NOTE: Do not use teflon tape on gas line pipe thread. A flexible sealant is recommended.

A minimum of 7" W.C. and a maximum of 14" W.C. upstream pressure under load, and no load conditions must be provided for natural gas, or a minimum of 12" W.C. and a maximum of 14" for propane.

ROBERTSHAW MILLIVOLT

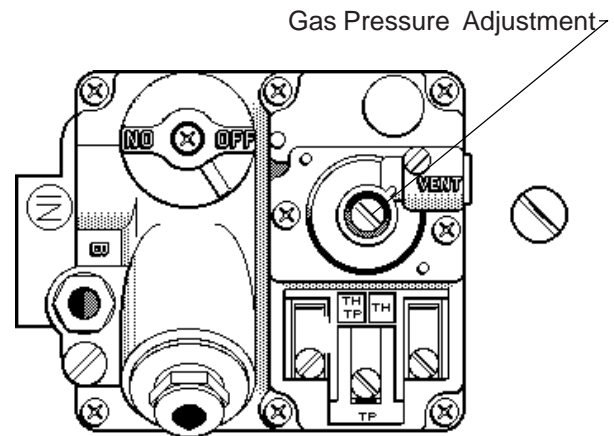

Fig. # 8199

HONEYWELL VALVE MILLIVOLT & IID

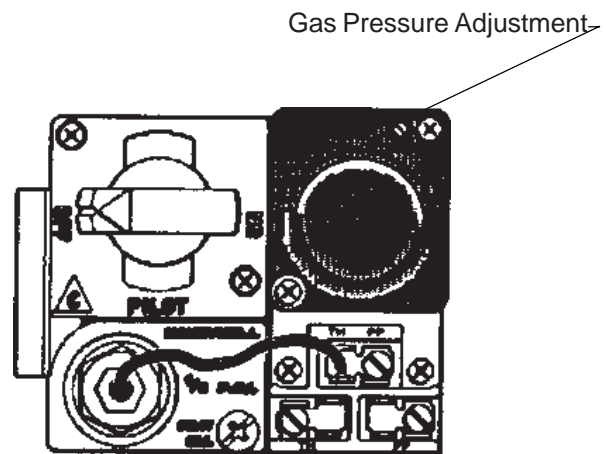



Fig. # 8081.0

PIPE SIZING FOR GAS CONNECTIONS

MAXIMUM EQUIVALENT PIPE LENGTH				
Natural Gas 1000 BTU/FT ³ .60 Specific Gravity @ 0.5" WC Pressure Drop				
Propane Gas 2500 BTU/FT ³ 1.53 Specific Gravity @ 0.5" WC Pressure Drop				
MODEL	1/2"		3/4"	
	N	P	N	P
055B	90	200	200	250

GAS PRESSURE REGULATOR

The gas pressure regulator is preset and sealed at 4" W.C. for natural gas, and 11" W.C. for propane. Between the gas valve and the burners is a 1/8" pipe plug. The pressure at this point, taken with a manometer, should be about 3.7" W.C. natural gas and 10.5" W.C. propane. If an adjustment is needed, remove seal and turn adjustment screw clockwise  to increase pressure or counter-clockwise  to decrease pressure.

PLUMBING FOR WATER CONNECTIONS

LOCATION

The VERSA heater requires water flow and positive pressure to fire and operate properly. It must therefore be installed downstream of the discharge side of the filter pump. A typical installation is plumbed as follows:

1. The inlet side of the filter is plumbed directly to the discharge side of the filter pump;
2. The outlet side of the filter is then plumbed to the inlet of the heater; and
3. The outlet of the heater is plumbed to the return line to the spa. The pump, filter and heater are thus plumbed in series.

Plumbing from the heater back to the spa must not have any valves or restriction that could prevent flow when the pump is operating. To do so will void the warranty.

Heater must be located so that any water leaks will not damage the structure of adjacent area. High temperature plastic pipe (CPVC) may be connected directly into the heater if local codes permit.

FLOW RATES

PIPE SIZE: 1 1/4"-1 1/2" MIN. GPM: 20, MAX. GPM: 60*

*When flow rates exceed 60 GPM an external auxiliary bypass valve is required. See External auxiliary bypass valve section for details.

COMPANION FLANGE CONNECTIONS

The inlet/outlet header flange accepts a 1 1/2" copper tube or 1 1/4" galvanized pipe as a slip connection directly into the manifold. The flange is also threaded for 1-1/2" pipe thread. 1-1/2" CPVC adapters (when available) can also be used.

DO NOT use petroleum base assembly fluids (such as petroleum jelly or lubricating oil). If assembly lube is required, use a silicone-based compound, such as Amoral, etc.

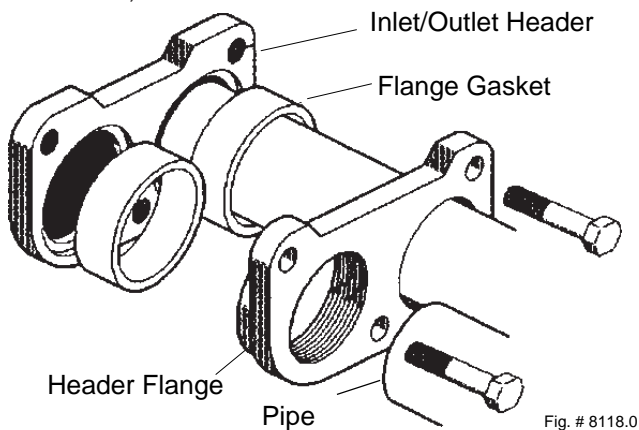

CAUTION: Never install PVC directly into header flanges. The initial connection must be made with a high temperature material such as CPVC or Copper.

For IID Pilots: PVC may be utilized immediately after the initial connections.

For Standing Pilots: Copper or high temperature CPVC pipe and two elbows are required between the heater and the PVC connections (heat sinks not supplied).

AUTOMATIC CHLORINATORS AND CHEMICAL FEEDERS

All chemicals must be introduced and completely diluted into the pool or spa water before being circulated through the heater. Do not place chlorine tablets or bromine sticks in the skimmer. High chemical concentrations will result when the pump is not running (e.g. overnight).

Chlorinators must feed downstream of the heater and have an anti-siphoning device to prevent chemical backup into the heater when the pump is shut-off.

NOTE: High chemical concentration from feeders and chlorinators that are out of adjustment will cause very rapid corrosion to the heat exchanger in the heaters. Such damage is not covered under the warranty.

UNITHERM GOVERNOR OPERATION

The patented Unitherm Governor is a thermostatic mixing valve specifically designed to maintain constant heater internal temperature between 105 - 115°F despite continually changing flow rates from the filter and changing pool temperatures. This narrow range is needed to prevent damaging condensation on the burners which will occur if the heater runs for any length of time below 100°F. It is also needed to inhibit scale formation in the tubes by maintaining temperatures well below accelerated scaling temperatures.

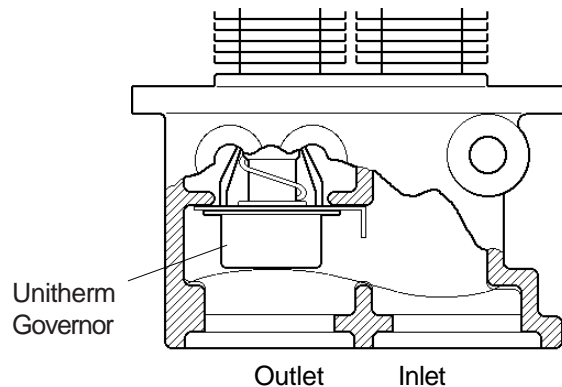

EXTERNAL AUXILIARY BYPASS VALVE (Where required)

An auxiliary bypass valve should be used when flow rates exceed 60 GPM (usually a high performance pump size larger than 1-1/2 HP will exceed this flow rate). This valve is required to complement the function of the automatic bypass valve, particularly when starting the heater in winter or early spring when the spa or pool temperature is down below 55°F. It also serves to eliminate needless pressure drop through the heater and accompanying reduction in the flow rate to the spa jets, etc.

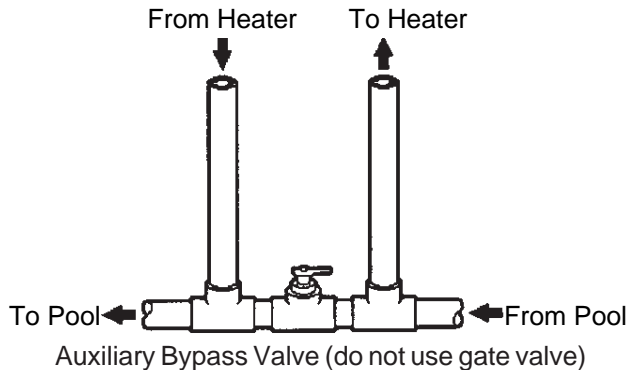

Fig. # 8150.0s

AUXILIARY BYPASS VALVE ADJUSTMENT

To set bypass: With clean filter, adjustment is made by feeling the inlet and outlet pipes at the heater. Outlet pipes should be slightly warmer than inlet and comfortable to the touch. If pipe is hot, close bypass; if cold, open bypass

PRESSURE RELIEF VALVE INSTALLATION

To conform to local building codes, it may be necessary to install a pressure relief valve. A 3/4" pressure relief valve having a capacity equal to BTUH/HR output of the model to be installed is recommended for this appliance.

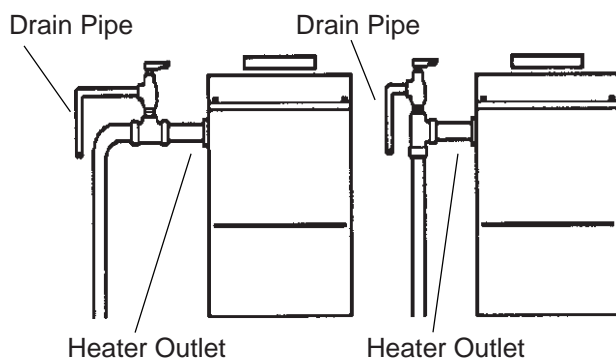

Fig. # 8157.0s

NOTE: To avoid water damage or scalding due to valve operation, drain pipe must be connected to valve outlet and run to a safe place of discharge. Drain pipe must be the same size as the valve discharge connection

throughout its entire length and must pitch downward from the valve. No shut-off valve shall be installed between the relief valve and the drain line. Valve lever should be tripped at least once a year to ensure that waterways are clear.

ELECTRICAL WIRING

NOTE: If it is necessary to replace any of the original wiring, it must be replaced with 105 °C wire or its equivalent, except all black wire must be replaced with 150 °C wire or its equivalent.

MILLIVOLT SYSTEM

The Millivolt System Residential Heater is equipped with a self-generating electrical system in which the electric current is provided by means of a pilot generator. No external electrical connections are required. When installing a remote switch, do not exceed 10 ft. of wiring from the heater. Use 18-gauge stranded wire.

ELECTRONIC INTERMITTENT IGNITION DEVICE (IID) SYSTEM

NOTE: When the electrical hookup to the heater requires both 24V and 120V or 240V, each input voltage must be isolated in a separate conduit.

The Electronic Intermittent Ignition Device automatically lights the pilot and main burners upon a call for the heat. The heater is supplied with a dual-voltage transformer for 120V or 240V input power hookup.

NOTE: IID Propane Units Only
Heater is equipped with an electronic ignition device with a 100% safety lockout feature. If the heater fails to start or lockout, reset the ignition device by interrupting the power to the heater for 60 seconds.

CAUTION: If service replacement of the electronic ignition device is required, replace only with a 100% safety lockout device with 90-second trial for pilot ignition.

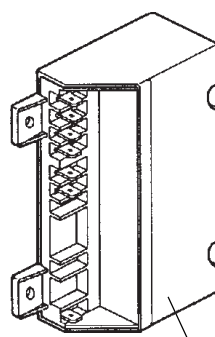

Fig. # 8929.1

Honeywell Intermittent Ignition Device

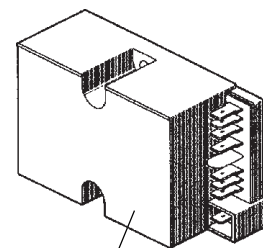

Fig. # 8085

Robertshaw Intermittent Ignition Device

For 120 V input power to the unit, connect the black wire to the "L1", or hot leg, of the power supply. Connect the white wire to the "L2", or neutral leg, of the power supply. Attach the wire nut to the red wire. There should be no connection to the red wire for 120V operation.

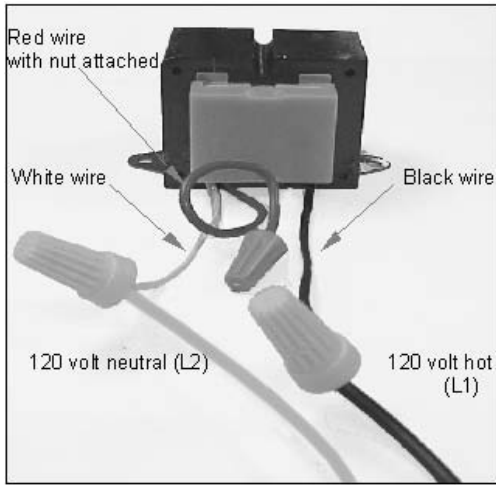

Fig. #9240

For 240 V input power to the unit, connect the black wire to the "L1", or hot leg, of the power supply. Connect the red wire to the "L2", or second hot leg, of the power supply. Attach the wire nut to the white wire. There should be no connection to the white wire for 240V operation.

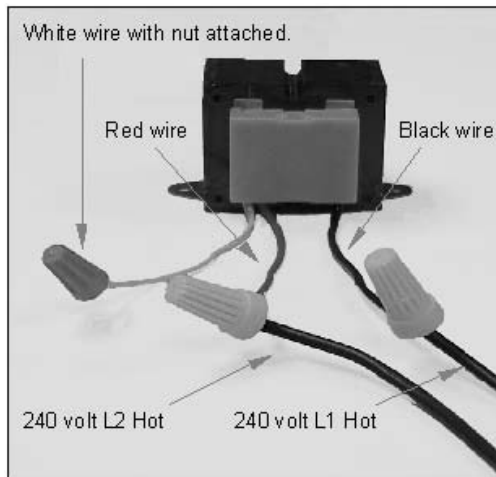

Fig. # 9241

Heater must be electrically grounded and bonded in accordance with local codes, or, in the absence of local codes, with the latest edition of the National Electrical code, ANSI/NFPA 70 (Canada-Canadian Electrical Code, CSA C221.1, Parts 1 and 2).

NOTE: Input power to the heater (120/240V) should be supplied from the load (pump) side of time clock or switch. Connecting heater to continuous power source will allow "Fail" indications (service and pressure switch) when pump is not operating.

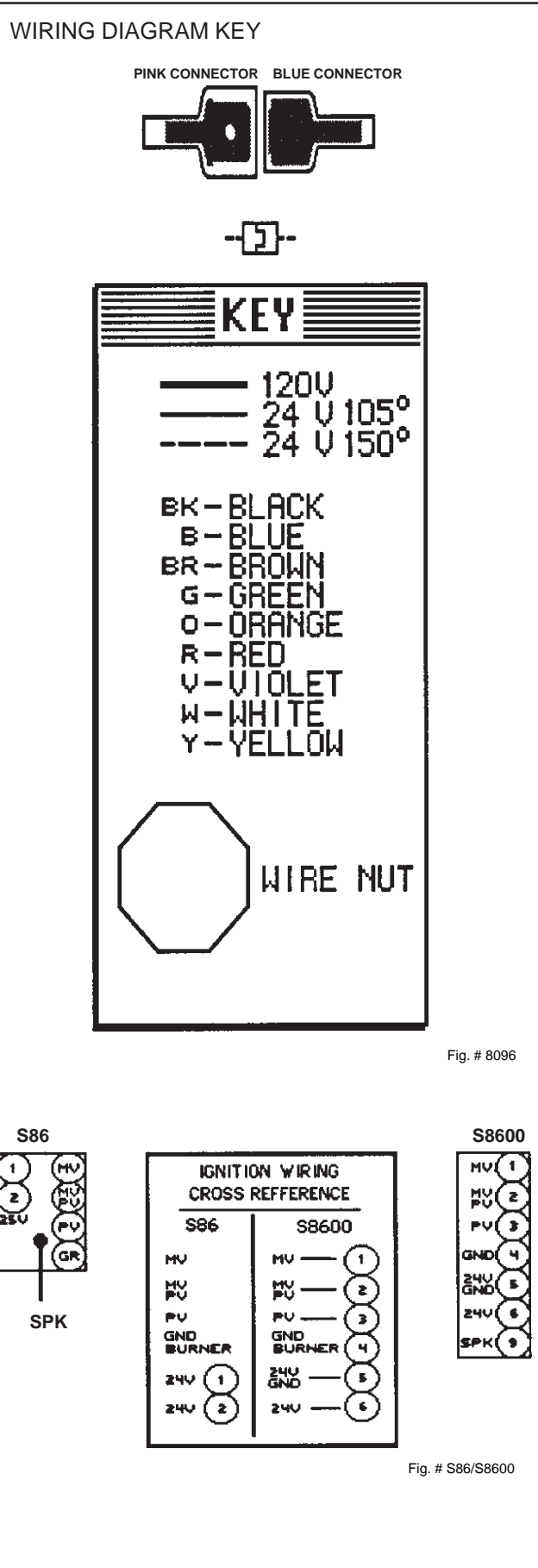

Fig. # 8096

Fig. # S86/S8600

WIRING DIAGRAMS

MILLIVOLT UNITS WITH MECHANICAL THERMOSTAT

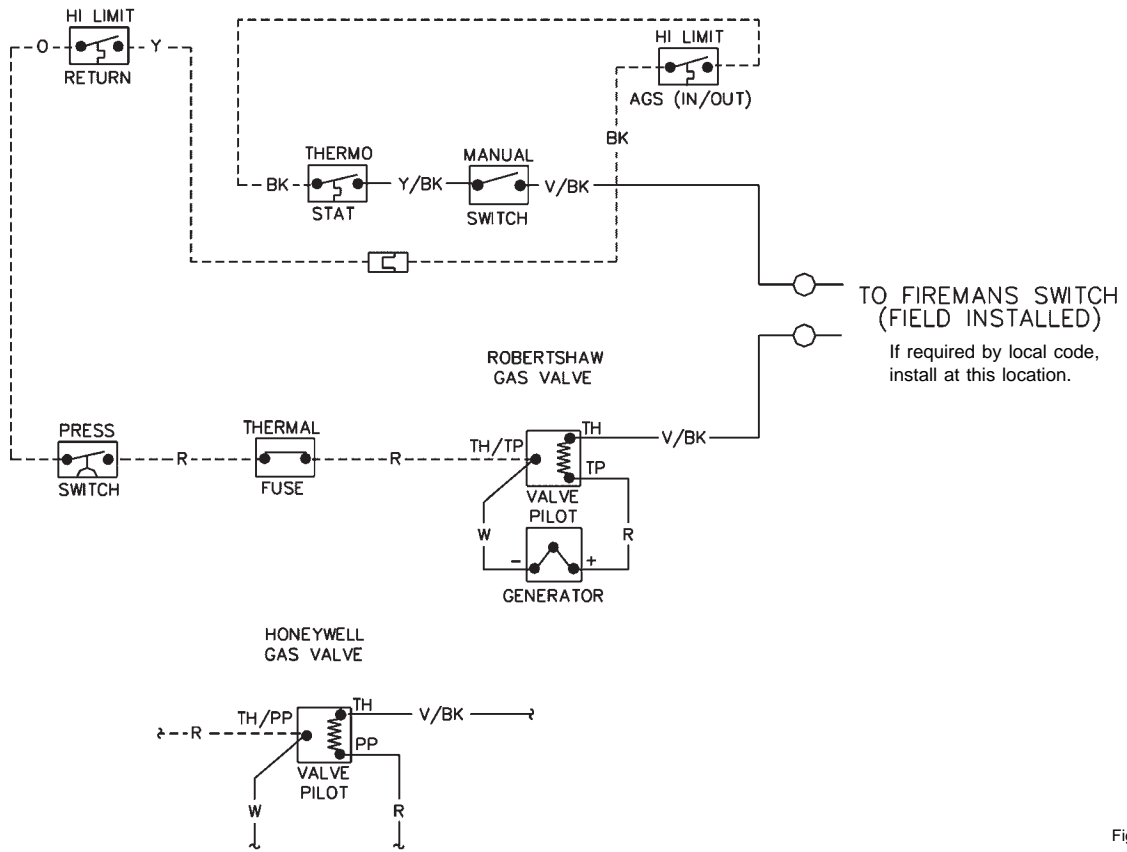
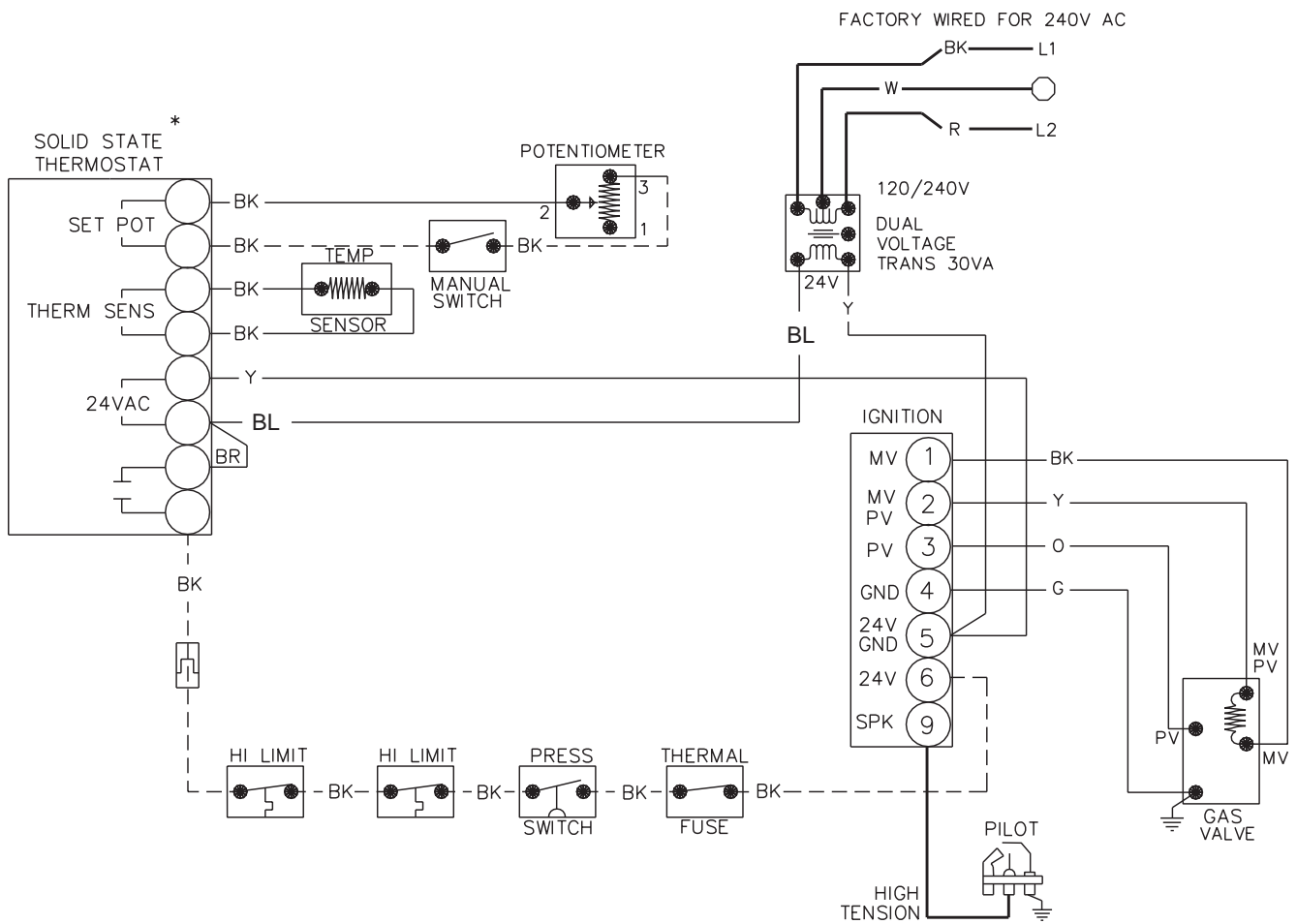
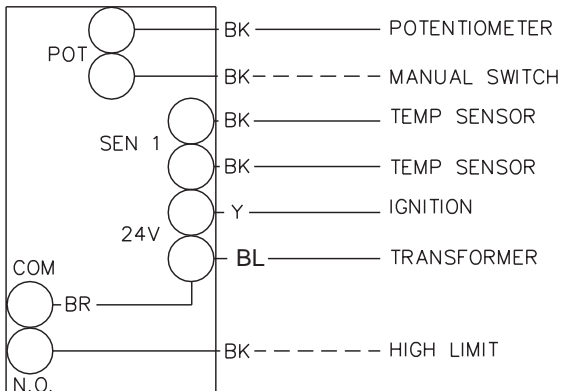

Fig. #2353

WIRING DIAGRAM IID UNITS



* ALTERNATE
SOLID STATE
THERMOSTAT



SECTION 4 / SERVICING INSTRUCTIONS

GENERAL LOCATION OF CONTROLS

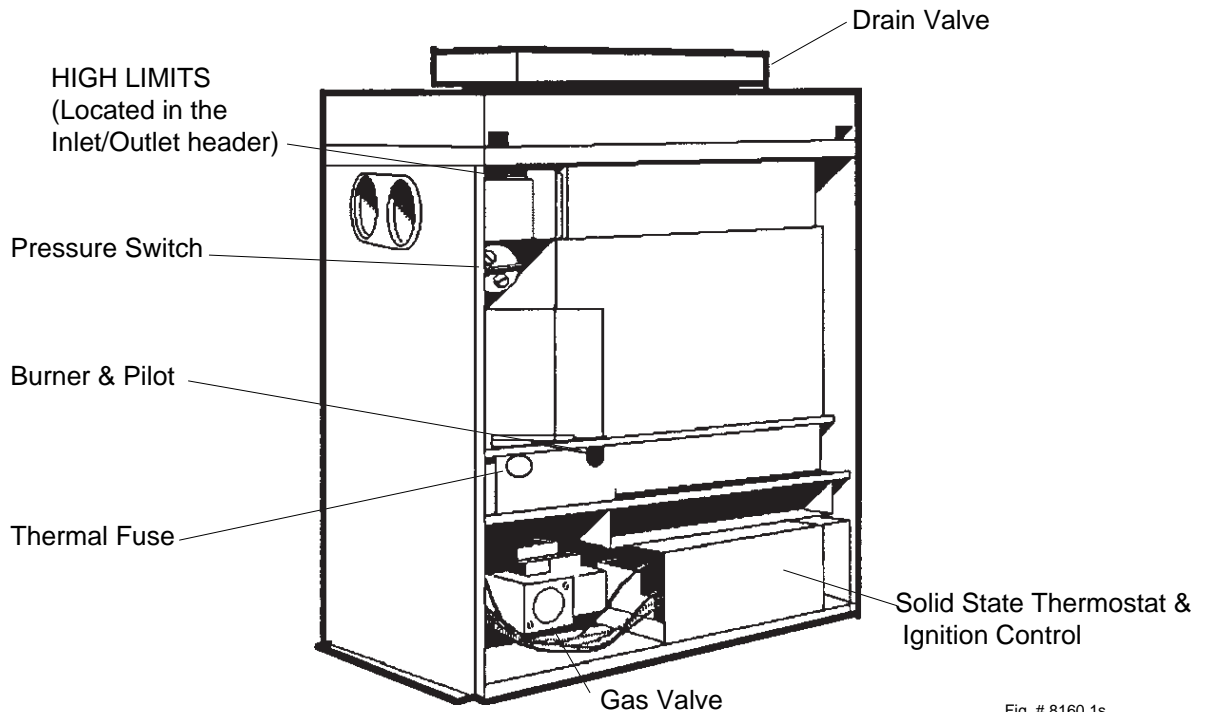

Fig. # 8160.1s

CONTROLS/ADJUSTMENTS/REPLACEMENTS

CAUTION: Label all wires prior to disconnection when servicing controls. Wiring errors can cause improper and dangerous operation. Verify proper operation after servicing.

DANGER - SHOCK HAZARD - Make sure electrical power to the heater is disconnected to avoid potential serious injury or damage to components.

TEMPERATURE CONTROLS

The water temperature is controlled by the heater thermostat on the upper front panel of the heater. The control center contains an On-off toggle switch and a thermostat. The switch functions as a means for turning the heater on or off.

The thermostat is fitted with a means of limiting the upper temperature limit below the maximum level. The knob stop adjustment ring illustrated above is adjustable by loosening the set screw, rotating the knobstop ring to the desired location and retightening the set screw.

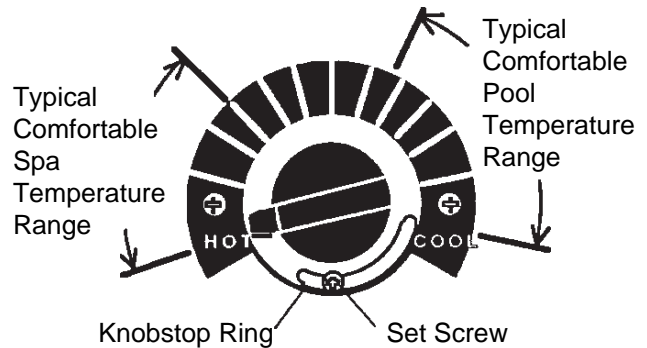

PRESSURE SWITCH

The pressure switch, or heater actuator, ensures that the heater operates only when the filter pump is in operation. It is factory set at 1.75 PSI for deck level installations. When the heater is located below the level of the spa or pool, it may be necessary to reset the pressure switch to compensate for the no-flow static head. If it is necessary to reset the pressure switch, we recommend the following procedure:

PRESSURE SWITCH ADJUSTMENT:

1. With pump and heater on, turn adjustment knob (clockwise) until a click is heard from the gas valve.
2. Turn adjustment knob (counter-clockwise) 1/4 turn.
3. Turn pump off and on several times. Heater should shut-off immediately. If it does not, repeat steps above until proper adjustment is made.

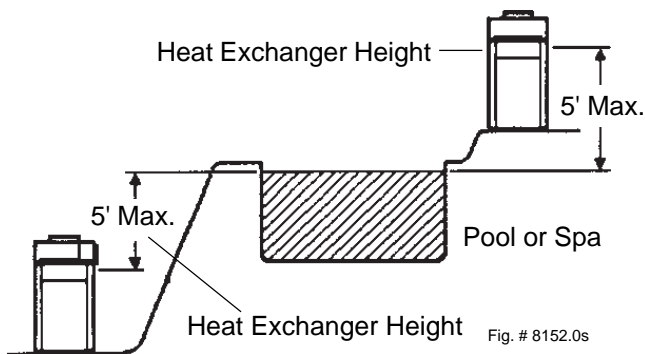
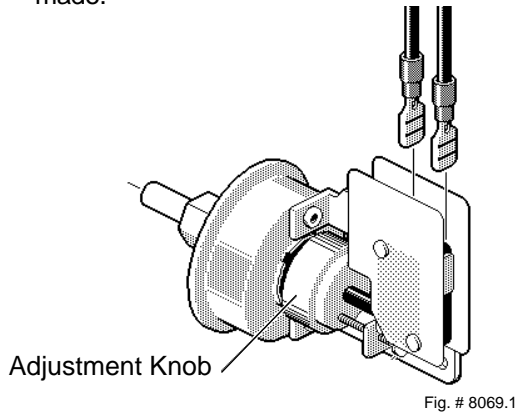

NOTE: If heater is installed outside of the limits shown, a flow switch must be used in place of the pressure switch when mounted and wired adjacent to the heater.

TWO-SPEED PUMPS

In some cases, the flow on the low-speed is insufficient to operate the heater. This is apparent when the pressure switch cannot be further adjusted or if the heater makes banging noises. In these cases, the pump must be run at high speed when heating the water.

CAUTION: Do not operate the heater without the function of a properly adjusted pressure switch.

FLAME ROLL-OUT SAFETY SWITCH

The heater is equipped with a thermal cut-off device to prevent flame roll-out in the event the heat exchanger becomes blocked. This is a "single-use" type fusible link or thermal fuse, that must be replaced when disabled by an over temperature condition, caused by excessive restriction in the heat exchanger flue passage.

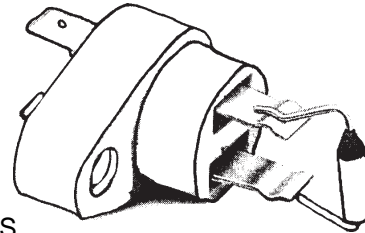

HIGH LIMITS

The heater is equipped with two automatic high limits, set to operate at 135°F and 140°F.

NOTE: An erratic high limit is often characteristic of internal heat exchanger problem, e.g. scale build-up, U.G. operation. Refer to Troubleshooting section, pg. 23.

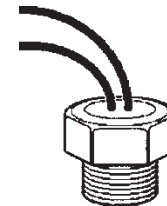

HIGH LIMIT REMOVAL

1. Disconnect top portion of unit. (See Heat Exchanger Removal procedure, steps 1 thru 7 and step 10 on pg. 21.)
2. Remove defective high limit and replace with new high limit.
3. Reverse above procedure to reinstall.

PILOT SAFETY

Millivolt Units

The heaters equipped with the standing pilot (millivolt system) have pilot generators which act as a safety device to shut-off the flow of gas to the main burners and the pilot burner in case the pilot flame is extinguished. The pilot burner must be manually relighted to place the heater in operation again. Refer to the lighting instructions provided on the heater label.

IID Units

The heater employs a pilot safety which closes the main gas valve within 8/10ths of a second whenever the pilot flame is interrupted. Pilot flame is automatically lit when the device is powered. Unit performs its own safety check and opens the main valve only after the pilot is proven to be lit.

BURNER TRAY REMOVAL

1. Shut-off main electrical power switch to heater.
2. Shut-off gas upstream of heater.
3. Remove front door.
4. Disconnect gas line from gas valve.
5. Remove (2) screws that mount burner tray to unit.
6. Disconnect wires that terminate at gas valve, and thermal fuse.
7. Slide out burner tray.
8. Reverse above procedure to reinstall.

GAS VALVE REMOVAL

1. Remove burner tray. (See Burner Tray Removal procedure).
2. Disconnect pilot tubing from gas valve.
3. Remove gas valve with manifold from burner tray.
4. Remove manifold from gas valve.
5. Reverse above procedure to reinstall.

MAIN BURNER AND ORIFICE REMOVAL

1. Remove burner tray. (See Burner Tray Removal procedure).
2. Remove screws and burner hold-down bracket.

NOTE: *If the heat exchanger is sooted badly, the burner hold-down bracket and spacer can become distorted from direct flame impingement and this usually necessitates replacement of these parts.*

3. Lift burners from slotted spacers and slide from orifices. Clean with a wire brush.
4. Orifices usually do not need to be replaced. To clean, run either copper wire or wood toothpick through orifice. Do not enlarge hole. To remove orifice, use a socket wrench and remove from manifold. **DO NOT** overtighten when reinstalling.

PILOT REMOVAL AND CLEANING

1. Remove burner tray. (See Burner Tray Removal procedure).
2. Disconnect pilot tubing, disconnect wires from gas valve.
3. Disconnect pilot bracket from burner shield.
4. Remove pilot from bracket.
5. Remove pilot orifice and air opening (Honeywell MILLIVOLT unit only), and clean with wire or small brush. **CAUTION! DO NOT** enlarge hole in pilot orifice.
6. Reverse above procedure to reinstall.

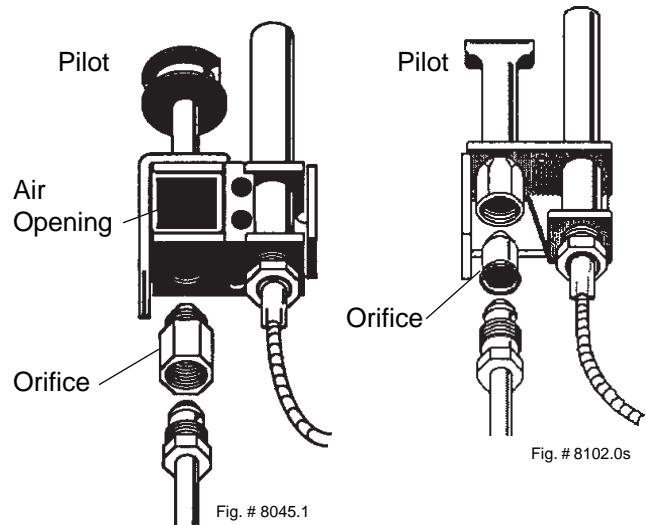

HONEYWELL PILOT

ROBERTSHAW PILOT

HEAT EXCHANGER REMOVAL

1. Shut water, gas, and electricity off, close valves and relieve pressure.
2. Drain heat exchanger.
3. Loosen and remove flange bolts.
4. Remove flange and inlet/outlet pipes from the header. Remove drain valve from rear header.
5. Remove outdoor stackless top or indoor stack top from unit.
6. Remove jacket top, flue collector, and baffle.
7. Remove upper front jacket panel, and disconnect wires at toggle switch.
8. Remove capillary bulb from inlet/outlet header.
9. Disconnect press switch tube from inlet/outlet header.
10. Disconnect high limit wire from thermostat, and pressure switch.
11. Lift heat exchanger straight up from combustion chamber, using caution not to damage refractory.
12. Reverse above procedure to reinstall.

DESOOTING PROCEDURE

CAUTION: SOOT IS COMBUSTIBLE. EXERCISE EXTREME CARE. NEVER USE A WIRE BRUSH.

Soot can clog areas between fins and cause eventual tube failure. Any sign of soot at the base of the burners or around the outer jacket indicates a need for cleaning.

1. Disconnect top portion of unit. (See Heat Exchanger Removal procedure steps 1 through 6).
2. Remove burner tray (See Burner tray Removal procedure.)
3. Take a garden hose and wash heat exchanger, making sure soot is removed completely from between fins. Avoid excessive water against refractory.

NOTE: In extreme cases it may be necessary to remove the heat exchanger completely for cleaning. The simplest method is steam cleaning at the local car wash. DO NOT WIRE BRUSH.

COMBUSTION CHAMBER REMOVAL

1. Remove heat exchanger (See Heat Exchanger Removal procedure).
2. Lift up and remove front and rear refractory shield.
3. Remove refractory panels.
4. Reverse above procedure to reinstall.



Fig. # 8155.0s

Refractory Panel Top View

CONTROL IMMERSION WELL REPLACEMENT

1. Remove plumbing and top portion of unit (See Heat Exchanger Removal procedure, steps 1 through 6).
2. Remove U.G. spring, U.G. and copper shield.
3. Collapse well tube at open end with chisel.
4. Push well up through header.
5. Insert new well and roll in place. If a roller is not available, solder the well in place with silver solder.

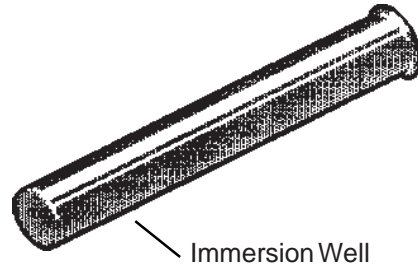

Fig. # 8126.0s

UNITHERM GOVERNOR (U.G.) REPLACEMENT

1. Shut water, gas and electricity off, close valves and relieve pressure.
2. Drain heat exchanger.
3. Disconnect inlet and outlet pipes with flange from in/out header.
4. Grasp retainer spring from inlet side of header, and slide thru inlet hole.
5. Remove shield.
6. Remove U.G. with seating gasket, and stainless steel baffle (not shown).
7. Reverse above procedure to re-install.

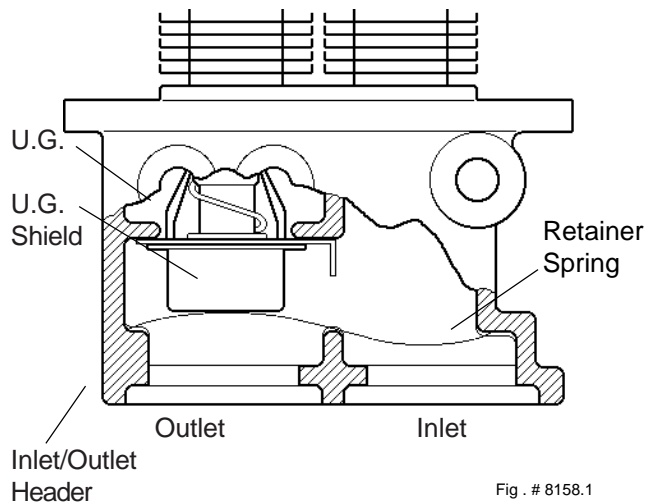

Fig. # 8158.1

To test the operation of the Unitherm Governor, place in hot water (over 110°F) and watch for movement against spring. If there is no movement, replace unit.

SECTION 5 / TROUBLESHOOTING GUIDE

IMPORTANT NOTICE

These instructions are primarily intended for use by qualified personnel specifically trained and experienced in the installation of this type of heating equipment and related system components. Installation and service personnel may be required by some states to be licensed. Persons not qualified shall not attempt to install this equipment nor attempt repairs according to these instructions.

MECHANICAL

<u>PROBLEM</u>	<u>CAUSE</u>	<u>SOLUTION</u>
Harmonics, or whining noise	U.G.inoperative.....	Check movement by putting in hot water (110°F or higher). If no movement, replace.
	*Debris or restriction in system.....	Locate the restriction and remove. Flush system and clean.
	*Debris in gas line.....	Remove debris or blow out gas line.
	Lowflow.....	Scale forming in heat exchanger - clean heat exchanger and check pool pH and total alkalinity.
Heater going on and off continuously	Dirty filter.....	Backwash filter.
	Low water level in pool.....	Raise water level.
	External bypass setting out of adjustment.....	Adjust bypass.
	*Pressure switch out of adjustment.....	Adjust pressure switch.
Liming or scale forming on heat exchanger	Pool water chemical imbalance....	See Water Chemistry on page 2.
Sooting	High flow rates.....	Reduce by adding manual bypass valve and adjust by putting thermometer in header (1/4" NPT) drain opening. Set bypass so thermometer reads between 105° and 110°F.
	U.G.inoperative.....	Check movement by putting in hot water (110°F or higher). If no movement, replace.
	*Airstarvation.....	Refer to installation instructions.
	*Improper venting.....	Follow recommended installation instructions.
	*Insects or debris clogging burner intake ports.....	Clean burners.
Pilot outage	Low gas pressure.....	Adjust gas pressure.
	Restricted pilot.....	Clean pilot.
	Weak pilot generator.....	Replace pilot.
Yellow lazy flame	Low gas pressure.....	Adjust gas pressure.
	*Insects or debris clogging burner intake ports.....	Clean burners.
Outer jacket very hot (paint blistered)	*Broken refractory caused by shipping damage or improper combustion.....	Replace refractory panels.
Takes long time to heat pool or spa	Excessive sooting of heat exchanger.....	Determine cause of sooting & correct.
	Undersized heater.....	Check heat rise per hour with the following formula: Heat rise (°/hr.)= $\frac{\text{Heater Output}}{\text{Pool Gallonage} \times 8.33}$
	Filter not running long enough.....	Reset time clock.
	Dirty filter.....	Clean filter.
	Gas line or meter undersized.....	Refer to installation instructions.

(* Usually occurs on initial start-up.)

Liming	Bypassing too much water.....	Inspect bypass for movement, if no movement, replace.
	U.G. not functioning.....	Replace if no movement when heated.
Leaking at well	Overacid.....	Replace well and maintain water chemistry properly.
Leaking at heat exchanger	Overacid.....	Replace heat exchanger and maintain chemistry properly.
Gasket brittle and leaking - (overheated)	Heater running after pump shuts off.....	See pressure switch adjustment.
	Refractory damage.....	Replace refractory.
	Sooted heater.....	Determine cause of sooting and correct.

ELECTRICAL -MILLIVOLT

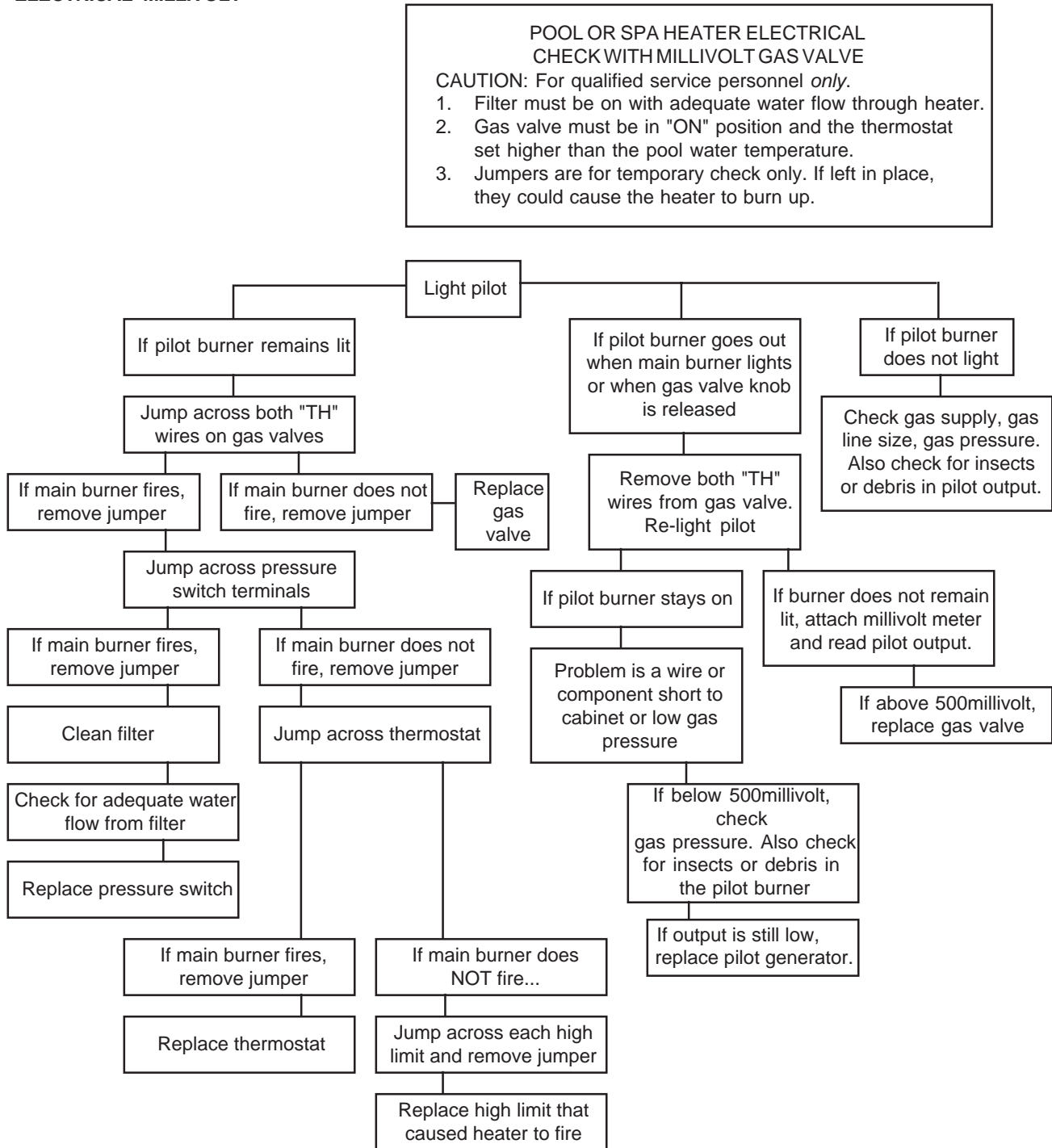

WARNING
HIGH VOLTAGE
 For qualified Technicians ONLY

NOTE: Some heaters may be equipped with an ignition module that shuts off pilot gas if pilot fails to light. To reset, interrupt power to heater.

Intermittent Pilot System
TROUBLESHOOTING HONEYWELL S8600

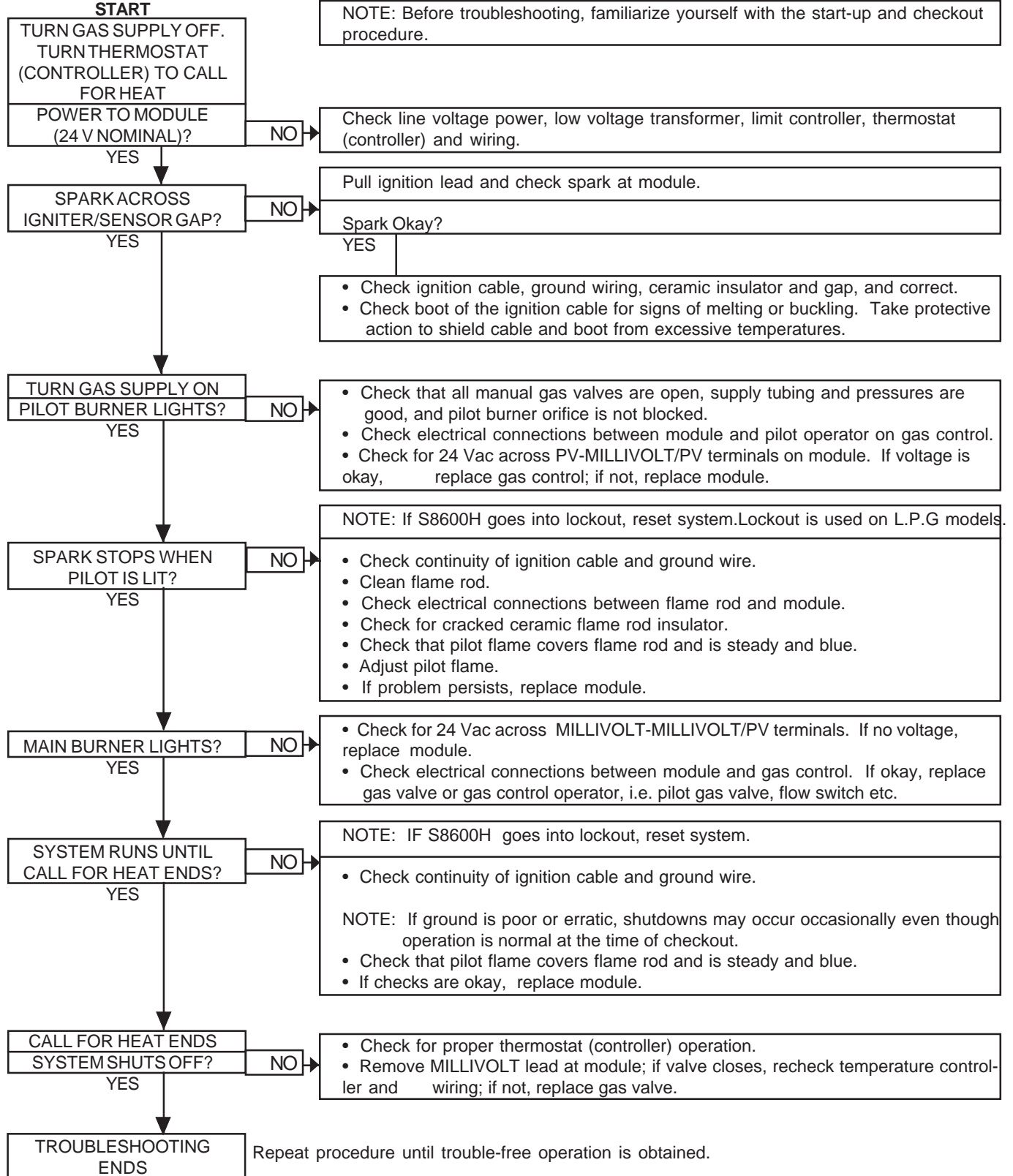

ELECTRICAL - IID, SOLID STATE THERMOSTAT

If the pool/spa/hot tub water is too cold, troubleshoot the system as follows:

Check voltage at 24 V terminals.

VOLTAGE BETWEEN 21.5-28.5 V.
Set control to max. temperature. After 2-3 cycles, check water temperature.

VOLTAGE OUTSIDE RANGE 21.5-28.5 V.
Check transformer, 120 V supply, correct as necessary

TEMPERATURE BELOW 105°F
Disconnect sensor leads from circuit board.
Measure sensor resistance with ohmmeter.

TEMPERATURE 105-106° F.
Control ok.

RESISTANCE 1-14k OHMS.
Check water temperature; estimate expected sensor resistance from chart below.

RESISTANCE 0 OHMS (SHORT CIRCUIT)
Check system for shorted wires or open circuits.
Replace sensor if necessary.

MEASURED AND ESTIMATED RESISTANCE MATCH WITHIN 20 PERCENT.
Disconnect potentiometer leads from circuit board.
Measure resistance with ohmmeter. If resistance is:
0-100 ohms at minimum setting and 9k to 11k at maximum setting, replace circuit board.
Above 11k ohms but less than 15 k ohms, replace potentiometer.
Above 15k ohms, fix loose or broken wires; replace potentiometer if necessary.
Reconnect all leads and check out system.

MEASURED AND ESTIMATED RESISTANCE DON'T MATCH.
Replace sensor. Reconnect all leads and check out system.

If the pool/spa/hot tub water is too hot, troubleshoot the system as follows:

Check voltage at 24 V terminals.

VOLTAGE BETWEEN 21.5-28.5 V.
Set control to max. temperature. After 2-3 cycles, check water temperature.

VOLTAGE OUTSIDE RANGE 21.5-28.5 V.
Check transformer, 120 V supply, correct as necessary.

TEMPERATURE ABOVE 108°F
Disconnect sensor leads from circuit board.
Measure sensor resistance with ohmmeter.

TEMPERATURE 105-106° F.
Control ok.

RESISTANCE 1-14k OHMS.
Check water temperature; estimate expected sensor resistance from chart below.

RESISTANCE ABOVE 15k OHMS (OPEN CIRCUIT) OR SHORT CIRCUIT.
Fix loose or broken wires. Replace sensor if necessary.

MEASURED AND ESTIMATED RESISTANCE MATCH WITHIN 20 PERCENT.
Disconnect potentiometer leads from circuit board.
Measure resistance with ohmmeter. If resistance is:
0-100 ohms at minimum setting: 9k to 11k at maximum setting, replace circuit board.
Above 11k ohms, replace potentiometer.
0 ohms (short circuit), replace potentiometer.
Reconnect all leads and check out system.

MEASURED AND ESTIMATED RESISTANCE DON'T MATCH.
Replace sensor. Reconnect all leads and check out system.

SENSOR RESISTANCE AT VARIOUS TEMPERATURES

Temperature (deg. F)	61	68	70	77	86	88	95	104	106
Resistance (k ohms)	14.92	12.49	11.88	10.00	8.06	7.69	6.53	5.33	5.10

SECTION 6 / REPLACEMENT PARTS LIST

NOTE: *In order to receive the correct part it is important that you state the model number, serial number and type of gas when applicable.*

Any part returned for replacement under standard company warranties must be properly tagged with return parts tag, completely filled in with the heater serial number, model number, etc., and shipped to the Company freight prepaid.

If determined defective by the Company and within warranty, the part will be returned in kind or equal substitution, freight collect. Credit will not be issued.

Manufacturer:

**2151 EASTMAN AVENUE
OXNARD, CA 93030**

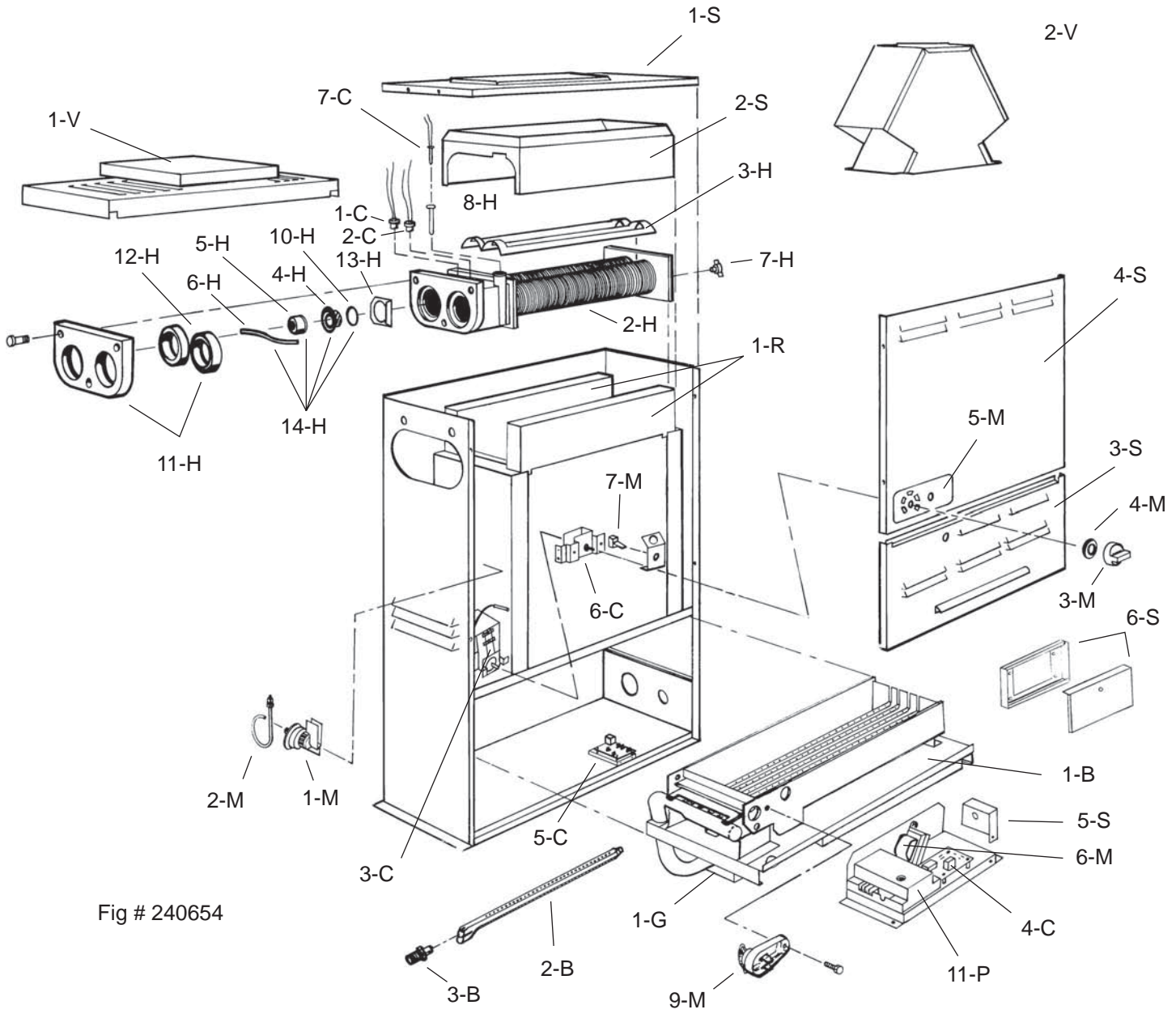

Fig # 240654

HONEYWELL MILLIVOLT PILOT

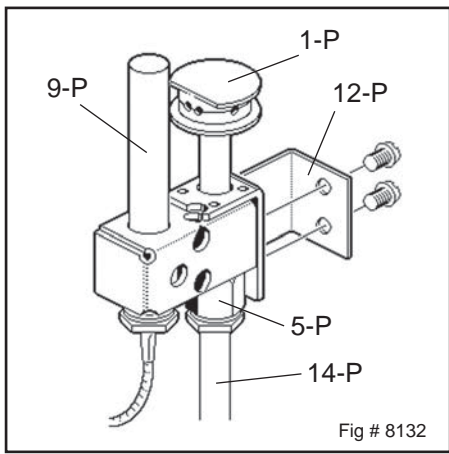

Fig # 8132

HONEYWELL IID PILOT

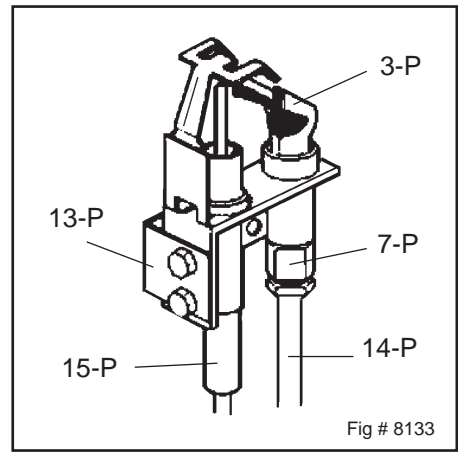

Fig # 8133

CALL OUT	DESCRIPTION	PREMIUM BRONZE
B	BURNER TRAY	
1-B	Burner Tray w/Burners (Sea Level)*	004688F
2-B	Burner	301210/4
3-B	Burner Orifice Nat. #52 (Sea Level)*	350081F/4
	Burner Orifice Pro. #62 (Sea Level)*	350086F/4
C	CONTROLS	
1-C	High Limit 135°F	600889B
2-C	High Limit 140°F	600890B
3-C	Thermostat Control MV (Mechanical)	003346F
8-C	Thermostat Control MV (Solid State)	005391F
5-C	PC Board	005089B
6-C	Potentiometer	005087B
7-C	Temperature Sensor	005088B
9-C	Thermostat Control IID (Solid State)	005390F
4-C	PC Board	005086B
6-C	Potentiometer	005087B
7-C	Temperature Sensor	005088B
G	GAS VALVE	
1-G	Combination Valve Nat. MV	003898F
	Combination Valve Pro. MV	003899F
	Combination Valve Nat. IID	003900F
	Combination Valve Pro. IID	004306F
H	HEAT EXCHANGER	
1-H	Heat Exchanger Assy. (Complete)	004694F
2-H	Header/Tubed Kit	004695F
3-H	Baffle Kit	004715F
14-H	U.G. Assy	002546F
4-H	Unitherm Governor	600885
5-H	U. G. Cap	400734
6-H	U. G. Spring	850247
10-H	U. G. Gasket	800276
7-H	Drain Valve	500719
8-H	Sensor Well	007211F
9-H	Bulb Retainer clip	300203
13-H	Bypass Baffle	306079
11-H	Inlet/Outlet Flange	002432F
12-H	Flange Gasket	800013B
M	MISCELLANEOUS COMPONENTS	
1-M	Pressure Switch	062237B
2-M	Pressure Switch Tube Assy.	003543F
3-M	Thermostat Knob	006885F
4-M	Knob Stop	006886F
5-M	Dial Plate MV	900741
	Dial Plate IID	900742
6-M	Transformer (IID Unit)	006736F
7-M	Toggle Switch	650595
8-M	Wire Harness MV	004010F
	Wire Harness IID	004011F
9-M	Thermal Fuse	008126F

*For altitudes above 2,000 feet above sea level, consult the factory.

CALL OUT	DESCRIPTION	PART NUMBER
P	PILOT	
1-P	Pilot Nat. MV	600525B
	Pilot Pro. MV	600575B
3-P	Pilot Nat. IID	002003F
	Pilot Pro. IID	002064F
5-P	Pilot Orifice Nat. MV	003901F
	Pilot Orifice Pro. MV	003902F
7-P	Pilot Orifice Nat. IID	003903F
	Pilot Orifice Pro. IID	004308F
9-P	Pilot Generator MV	600019B
11-P	Ignition Control IID Nat.	004817B
	Ignition Control IID Pro.	004818B
12-P	Pilot Mounting Bracket IID	004716F
13-P	Pilot Mounting Bracket MV	004717F
	Pilot Tube	004078F
15-P	Hi Tension Wire IID	002654B
	Hi Tension Wire w/Pilot Electrode	007864F
R	REFRACTORY	
1-R	Refractory Block Kit	003544F
S	SHEETMETAL	
1-S	Jacket Top	002525F
2-S	Flue Collector	002530F
3-S	Door Assy.	004689F
4-S	Upper Jacket Control Panel	003791F
5-S	Wiring Box	306094
6-S	Thermostat Lock/Cover	006492
V	VENTING	
1-V	Stackless Top (Outdoor)	003709
2-V	Draffhood (Indoor)	003722

CONVERSION KITS**		
Gas Conversions		
Nat. to Pro. MV Units		004696B
Pro. to Nat. MV Units		004697B
Nat. to Pro. IID Units		NA
Pro. to Nat. IID Units		NA

**** Gas Conversions are to be done only by a qualified agency.**

